

Products

32020	32030
32021	32031
32022	32032
32023	32033
32024	32034

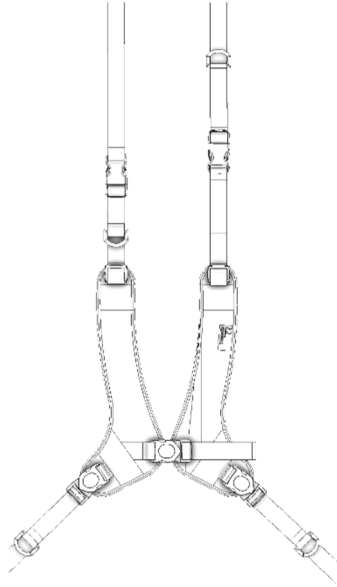

Document 08586
Revision A 4-2023



2. English

To provide support to the torso of a wheelchair user to promote upright posture. Not intended as a restraint in a moving vehicle.

7. Nederlands

Dutch

Om de romp van een rolstoelgebruiker te ondersteunen om een rechtopstaande houding te bevorderen. Niet bedoeld als beperking in een rijdend voertuig.

12. Français

French

Fournir un soutien au torse d'un utilisateur de fauteuil roulant pour favoriser une posture droite. N'est pas conçu comme dispositif de retenue dans un véhicule en mouvement.

17. Deutsch

German

Stützt den Oberkörper eines Rollstuhlfahrers, um eine aufrechte Körperhaltung zu fördern. Nicht als Rückhaltesystem in einem fahrenden Fahrzeug gedacht.

22. Italiano

Italian

Fornire supporto al busto di un utente su sedia a rotelle per promuovere la postura eretta. Non inteso come trattenuta in un veicolo in movimento.

37. Español

Spanish

Para proporcionar apoyo al torso de un usuario de silla de ruedas para promover la postura erguida. No está diseñado como restricción en un vehículo en movimiento.

Pivot Point Harness

English

Image below shows installed device.

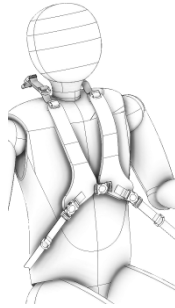

Product Identification

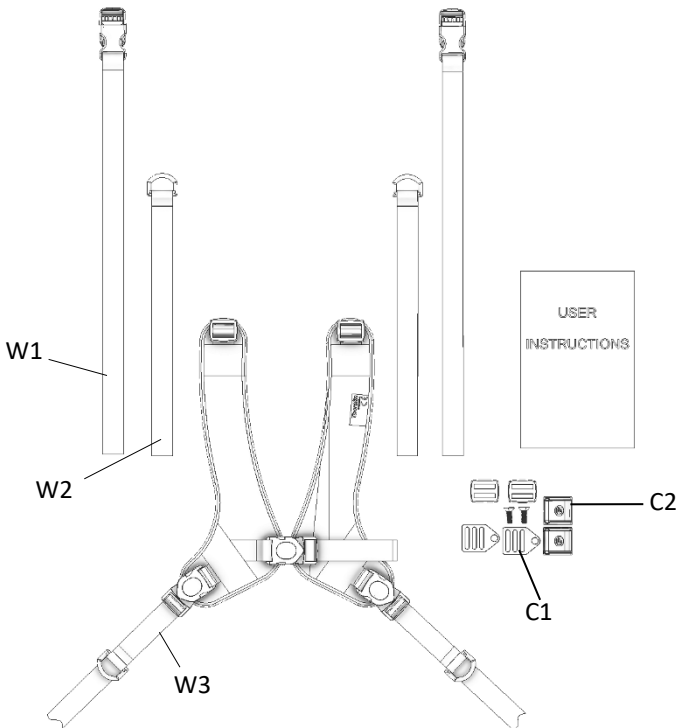

Pivot Point Harness

Setup:

Choose Front Pull or Rear Pull

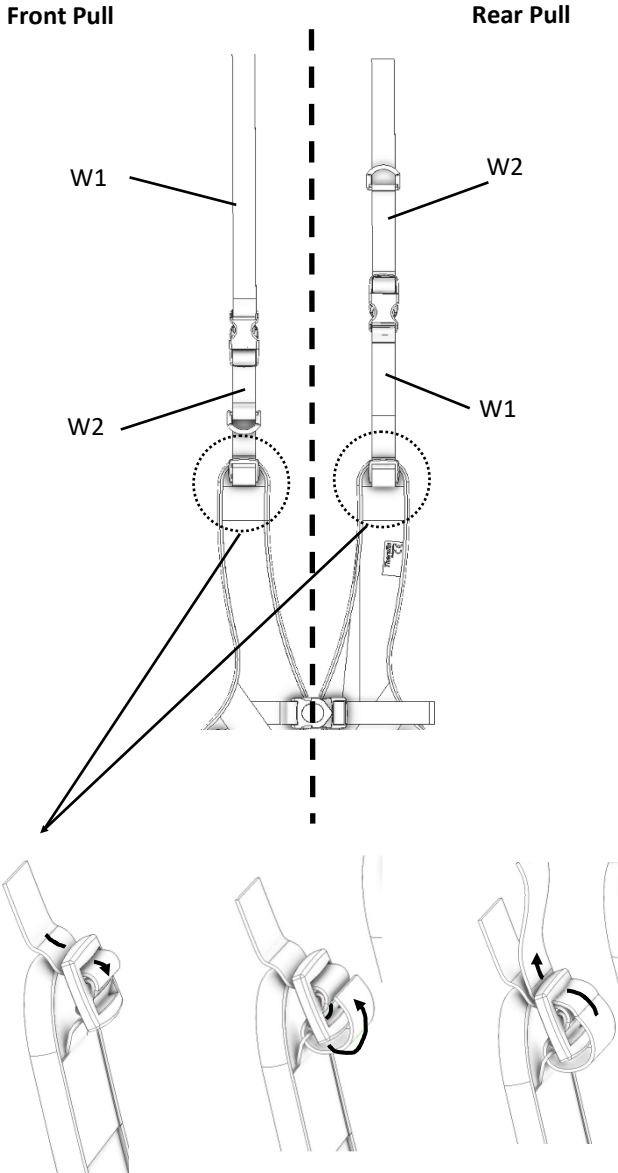

Pivot Point Harness



Caution: Read Instructions before operating device.



Caution: Device should be installed by a trained wheelchair technician.



Caution: Device should be attached to a wheelchair back that conforms with ISO16840-3 or equivalent.



Caution: Use caution when installing, removing or adjusting device to avoid pinching or trapping fingers.



Caution: Always tighten all fasteners securely and inspect fasteners regularly for tightness.



Warning: This device is NOT intended as an occupant restraint in a moving vehicle. This device is for positioning use only and should not be relied upon as a transit safety restraint. Use only WC-3 tested products for occupant restraint in a moving vehicle.



Warning: This device should be worn properly. Position the device properly to avoid choking hazard. Device should always be used with a hip positioning belt.

To Install:

Step 1: Identify attaching method:

2 Clips and 2 Cams (C1 and C2)

Step 2: Feed webbing (W1) through clips (C1) and W3 through cams (C2).

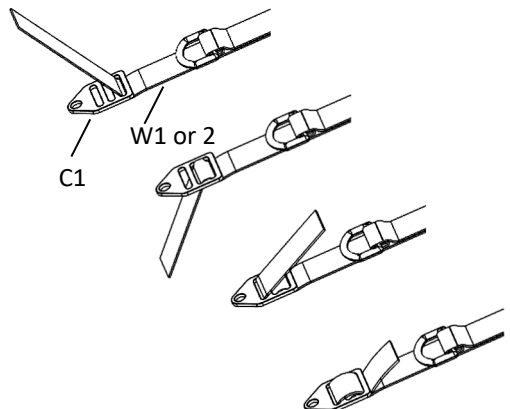
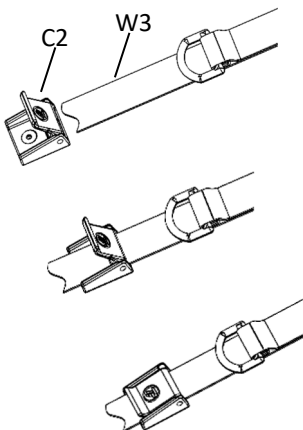

Pivot Point Harness

Step 3: Position device on patient. Do not place too high near neck.



Warning: This device should be worn properly. Position the device properly to avoid choking hazard. Device should always be used with a hip positioning belt.

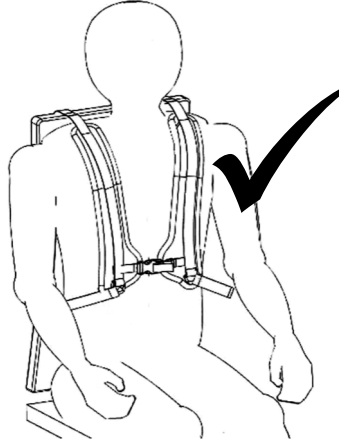
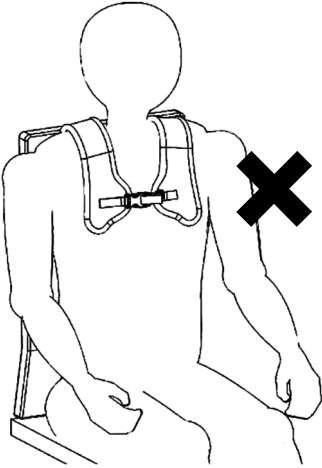

Step 4: Attach clips (C1) and cams (C2) to wheelchair back.
Tighten fasteners.

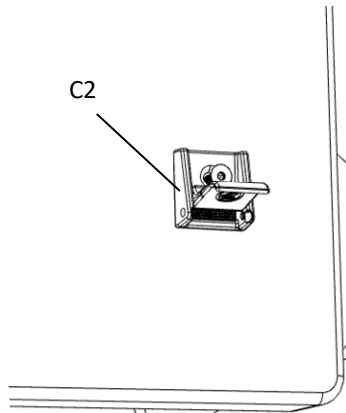
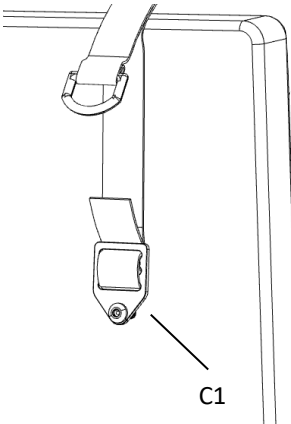

Pivot Point Harness

To Adjust:

 **Warning:** This device should be worn properly. Position the device properly to avoid choking hazard. Device should always be used with a hip positioning belt.

Once all clips (C1) and cams (C2) are secured, tighten straps by pulling on D-Ring. Be sure Harness is NOT positioned too high near neck.

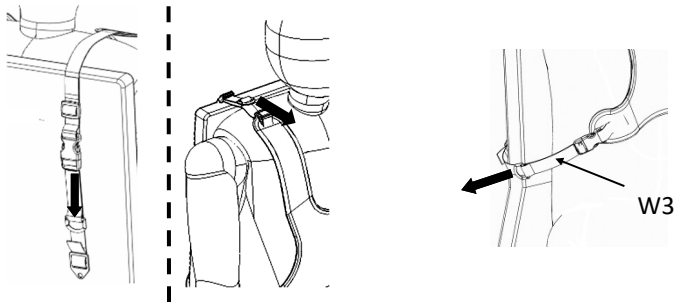

Care and Cleaning

 **Caution:** Always tighten all fasteners securely and inspect fasteners regularly for tightness.

1. Clean with mild detergent and water using damp cloth. Air Dry.



2. Check all fasteners and retighten as needed.

Warranty

Any product found to be defective due to the material or workmanship within one year will be replaced under our return policy following product evaluation by Therafin Corporation. This replacement warranty does not include misuse or neglect of the product.

Notices

If patient experiences any skin irritation or severe discomfort contact your healthcare professional or medical technician.

If any serious incident or injury occurs please contact Therafin Corp and the competent authority for your country

Document 08586

Revision A 4-2023



Therafin Corporation
9450 W Laraway Road
Frankfort, IL 60423 USA
800-843-7234
www.therafin.com



MedEnvoy Global B.V.
Prinses Margrietplantsoen
33- Suite 123
2595 AM The Hague
The Netherlands

Pivot Point Harness

Nederlands (Dutch)

Afbeelding hieronder toont geïnstalleerde apparaat.

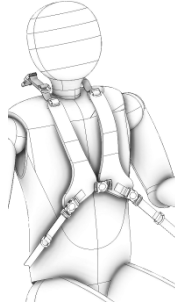

Productidentificatie

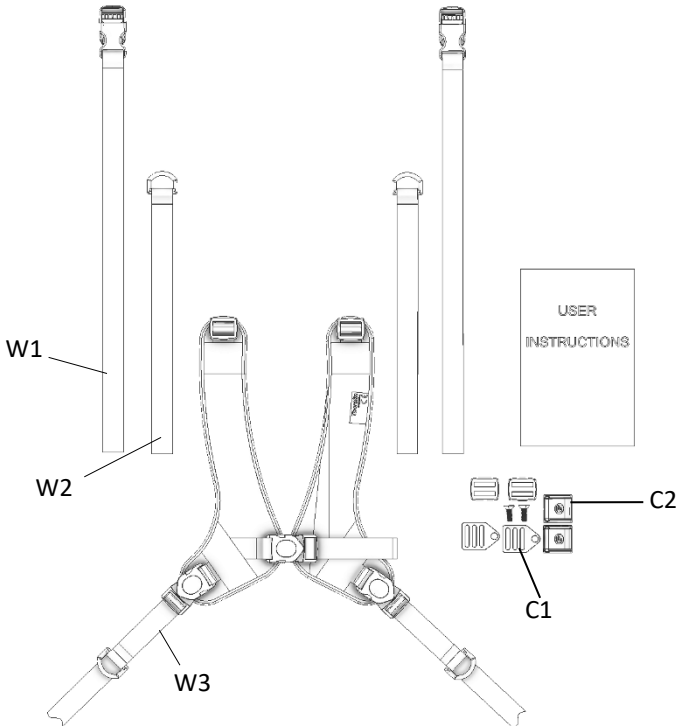

Pivot Point Harness

Opgericht:

Kies Front-Pull of Rear-Pull

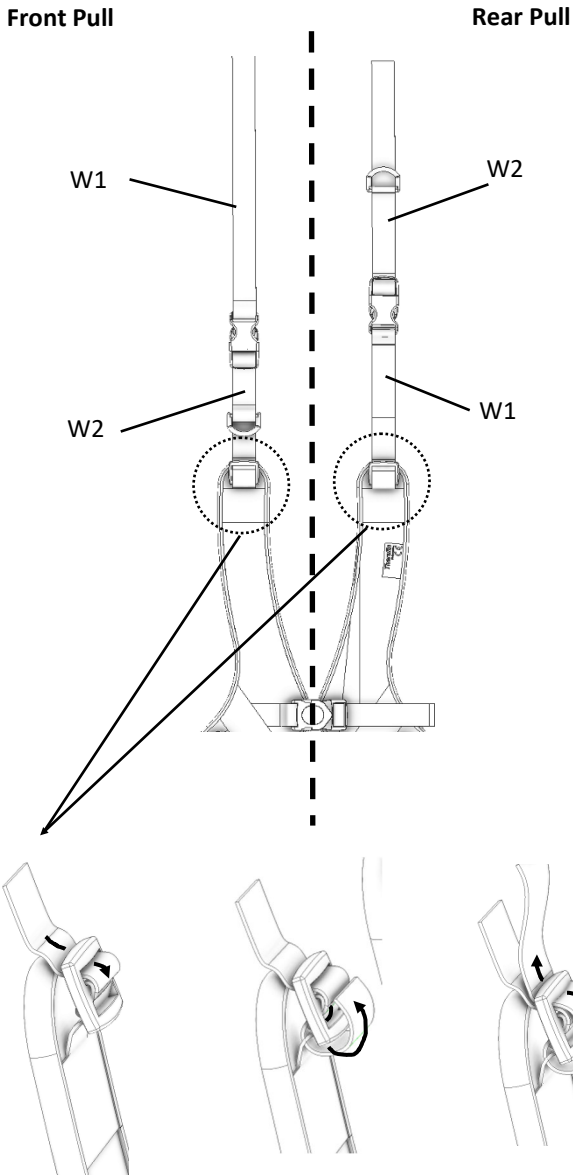

Pivot Point Harness



Opgelet: Lees de instructies voordat u het apparaat gebruikt.



Opgelet: Het apparaat moet door een deskundige worden geïnstalleerd.



Opgelet: Het apparaat moet aan de rug van een rolstoel worden bevestigd die aan ISO16840-3 of gelijkaardig beantwoordt.



Opgelet: Wees voorzichtig bij het installeren, verwijderen of aanpassen van het apparaat, zodat uw vingers niet bekneld geraken.



Opgelet: Draai alle sluitingen altijd goed vast en controleer deze regelmatig om te zien of deze nog goed vastzitten



Waarschuwing: Dit apparaat is niet bedoeld als Inzittende opsluitstelsel in een bewegend voertuig. Dit apparaat is alleen positionering gebruik en mag niet worden ingeroepen als doorvoer- beveiligingssystemen. Gebruik alleen WC-3 geteste producten voor de inzittenden in een bewegend voertuig.



Waarschuwing: Dit apparaat moet goed worden gedragen. Plaats het apparaat goed te vermijden verstikkingsgevaar opleveren. Apparaat moet altijd worden gebruikt met een hippe positionering riem.

Installeren:

Stap 1: identificeer de bevestigingsmethode:

2 clips (C1) en 2 nokken (C2)

Stap 2: Voer band (W1) door clips (C1) en W3 door nokken (C2).

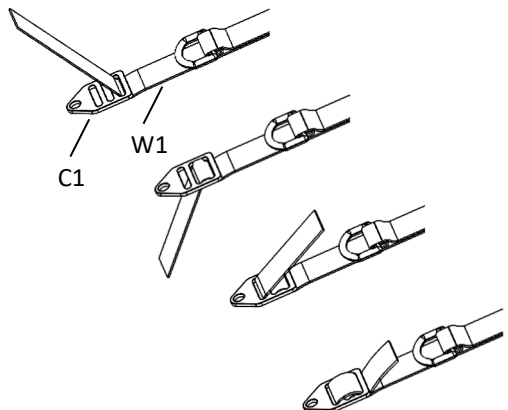
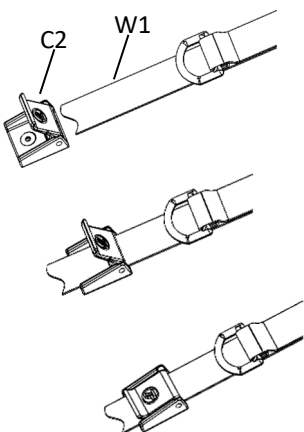

Pivot Point Harness

Stap 3: Positie apparaat op de patiënt. Plaats geen te hoog in de buurt van de nek.



Waarschuwing: Dit apparaat moet goed worden gedragen. Positie het apparaat correct te vermijden verstikkingsgevaar opleveren. Apparaat moet altijd worden gebruikt met een hippe positionering riem.

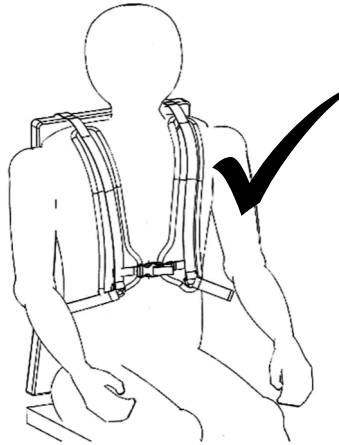
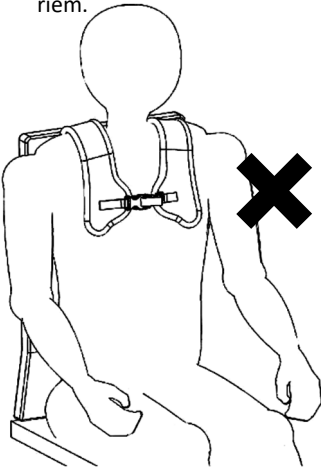

Stap 4: Bevestig de clips (C1) en nokken (C2) voor rolstoelgebruikers terug. Draai de bevestigingen.

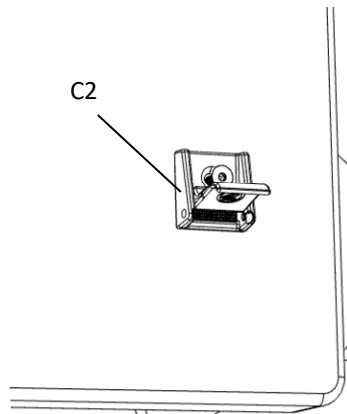
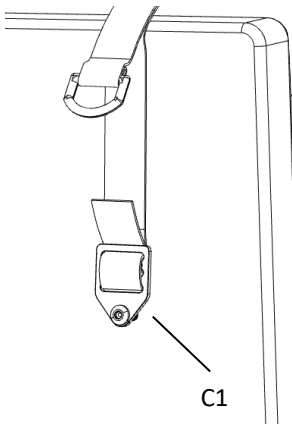

Pivot Point Harness

Afstelling:

Zodra alle clips (C1) en nokken (C2) zijn bevestigd, riemen aan te passen door te trekken op de D-Ring. Zorg ervoor vest wordt NIET geplaatst te hoog in de buurt van de nek.



Waarschuwing: Dit apparaat moet goed worden gedragen. Positie het apparaat correct te vermijden verstikkingsgevaar opleveren. Apparaat moet altijd worden gebruikt met een hippe positionering riem.

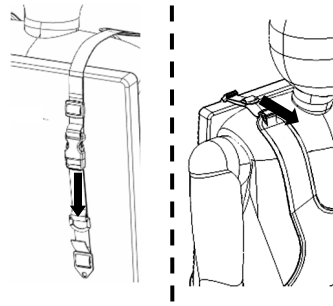

Onderhoud en reiniging



Opgelet: Draai alle sluitingen altijd goed vast en controleer deze regelmatig om te zien of deze nog goed vastzitten.

1. Schoon met zachte zeep en water met behulp van een vochtige doek. Luchtdroog.

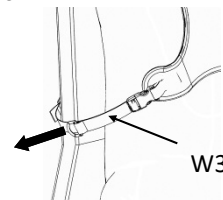

2. Controleer alle bevestigingen en draai als nodig is.

Mededelingen

Als de patiënt huidirritatie of ernstig ongemak ervaart, neem dan contact op met uw zorgverlener of medisch technicus.

Als er zich een ernstig incident of letsel voordoet, neem dan contact op met Therafin Corp en de bevoegde autoriteit voor uw land

Het product is gemaakt van materialen die zonder speciale voorzorgsmaatregelen veilig kunnen worden weggegooid.

Document 08586

Revision A 4-2023



Therafin Corporation
9450 W Laraway Road
Frankfort, IL 60423 USA
800-843-7234
www.therafin.com

Garantie

Elk defect onderdeel als gevolg van materiaal of vakmanschap dat het eerste jaar optreedt, zal worden vervangen

volgens ons retourbeleid en na beoordeling door Therafin Corporation. Deze garantie geldt niet voor misbruik of verwaarlozing van het product.



MedEnvoy Global B.V.
Prinses Margrietplantsoen 33- Suite 123
2595 AM The Hague
The Netherlands

Pivot Point Harness

Français (French)

Image ci-dessous montre dispositif installé.

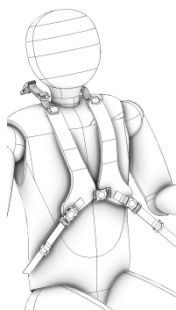

Identification du produit

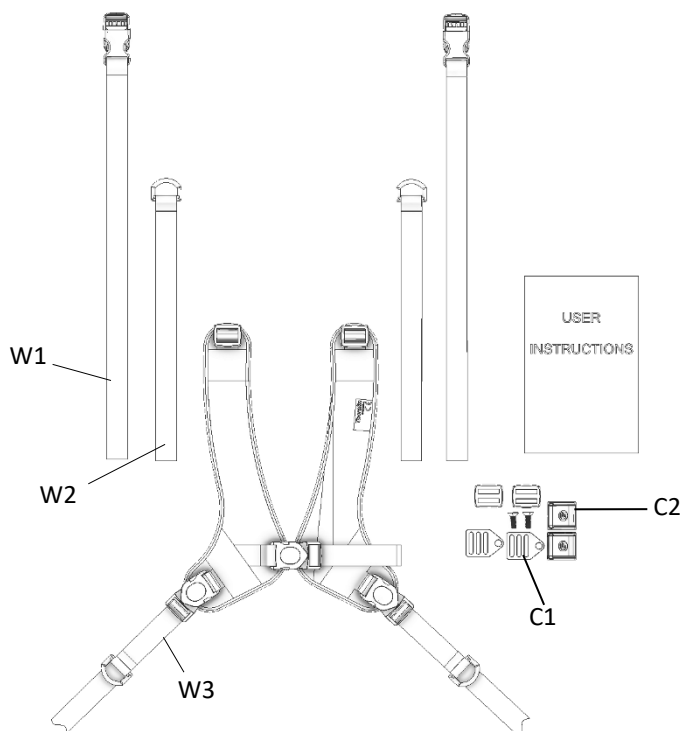

Pivot Point Harness





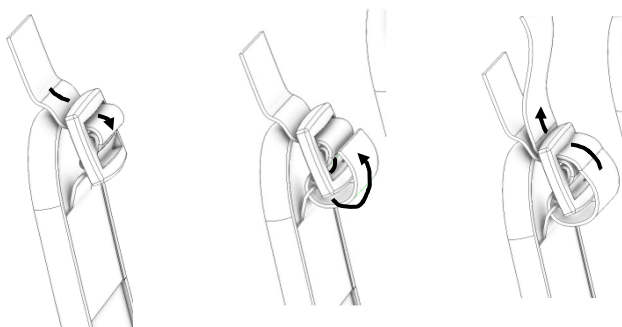
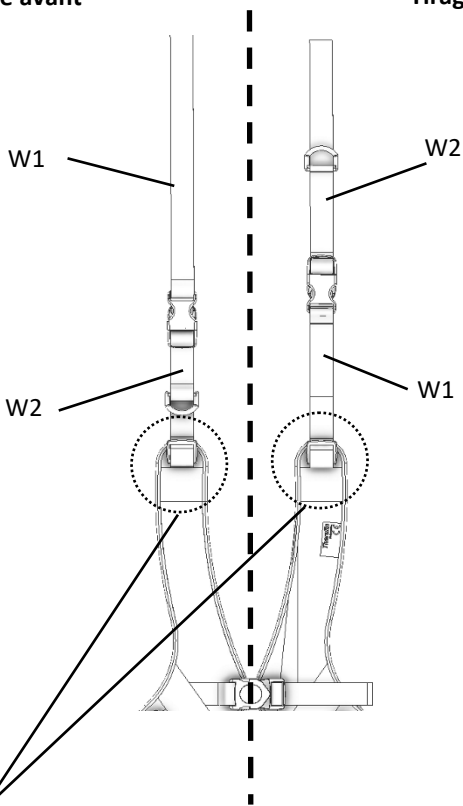

Installation:

Choisissez la traction avant ou la traction arrière

Tirage avant **Tirage arrière**



Pivot Point Harness

-  Prudence : Lisez attentivement toutes les instructions avant d'utiliser ce dispositif.
-  Prudence : Ce dispositif doit être installé par un technicien de fauteuil roulant qualifié.
-  Prudence : Ce dispositif doit être fixé à un dossier de fauteuil roulant qui est conforme à la norme ISO16840-3 ou une norme équivalente.
-  Prudence : Faites preuve de précautions lorsque vous installez, retirez ce dispositif, ou lorsque vous y effectuez des réglages pour ne pas vous pincer ou piéger les doigts.
-  Prudence : Serrez toujours tous les boulons de fixation de façon sécuritaire et vérifiez-les régulièrement pour vous assurer qu'ils sont solidement serrés.
-  Attention: Ce dispositif ne vise pas à un dispositif de sécurité des occupants dans un véhicule en mouvement. Ce dispositif est à usage de positionnement seulement, et ne devrait pas être invoquée en tant que dispositif de sécurité du véhicule. Utilisez uniquement des WC-3 produits testés pour la retenue des occupants dans un véhicule en mouvement.
-  Attention: Cet appareil doit être porté correctement. Placez l'appareil correctement pour éviter les risques d'étouffement. Appareil doit toujours être utilisé avec une ceinture de positionnement de la hanche.

Installer:

Étape 1: Identifiez la méthode de fixation :

2 clips et 2 cames (C1 et C2)

Étape 2: Faites passer la sangle (W1) dans les clips (C1) et W3 dans les cames (C2).

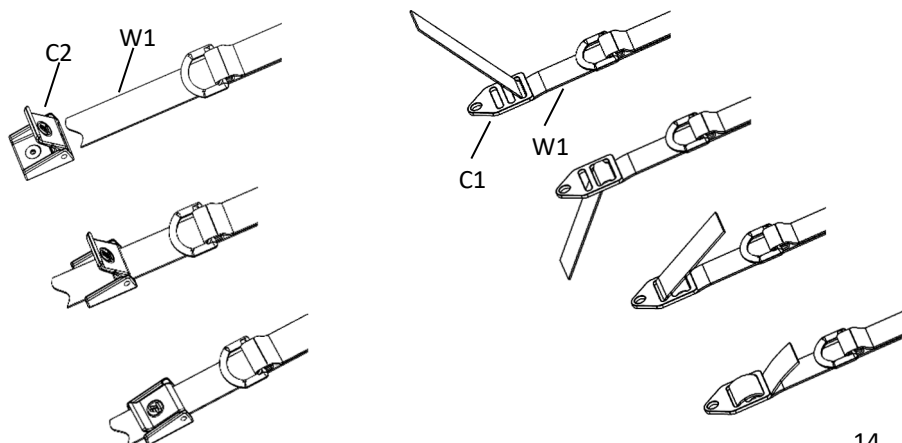

Pivot Point Harness

Étape 3: Dispositif de position sur le patient. Ne placez pas trop haut près de la gorge.

 Attention: Cet appareil doit être porté correctement. Placez l'appareil correctement pour éviter les risques d'étouffement. Appareil doit toujours être utilisé avec une ceinture de positionnement de la hanche.

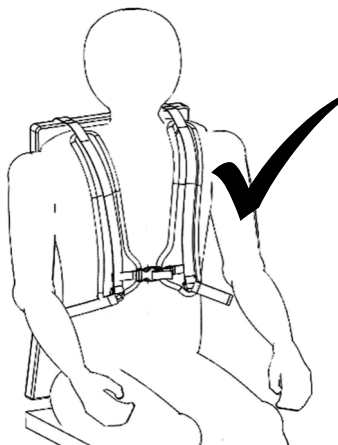
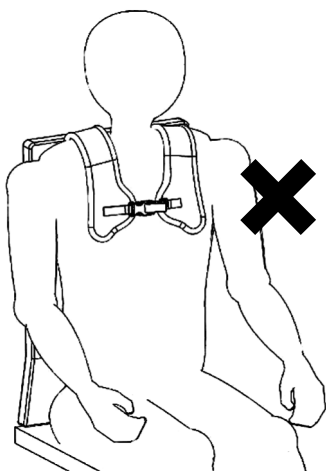

Étape 4: Joindre clips (C1) et comes (C2) à fauteuil roulant dos. Serrer les fixations.

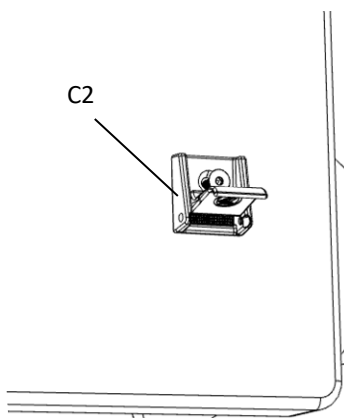
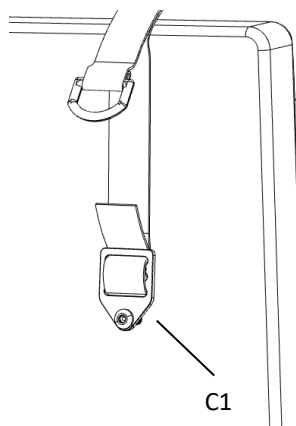

Pivot Point Harness

Ajuster:

Une fois que tous les clips (C1) et cames (C2) sont fixés, serrez les sangles en tirant sur D-Ring. Soyez sûr gilet est pas positionné trop haut près de la gorge.



Attention: Cet appareil doit être porté correctement. Placez l'appareil correctement pour éviter les risques d'étouffement. Appareil doit toujours être utilisé avec une ceinture de positionnement de la hanche.

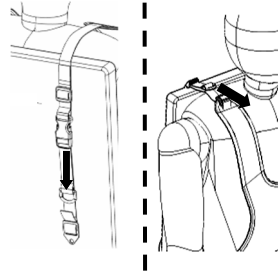

Prudence : Serrez toujours les boulons de fixation de façon sécuritaire, et vérifiez-les régulièrement pour vous assurer qu'ils sont bien serrés.

1. Nettoyer avec un détergent doux et d'eau avec un chiffon humide. Sécher À L'Air.

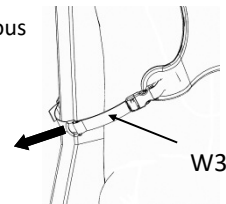

2. Vérifiez toutes les fixations et resserrer au besoin.

Avis

Si le patient ressent une irritation de la peau ou un inconfort grave, contactez votre professionnel de la santé ou votre technicien médical.

En cas d'incident ou de blessure grave, veuillez contacter Therafin Corp et l'autorité compétente de votre pays

Le produit est fait de matériaux qui peuvent être éliminés en toute sécurité sans précautions particulières.

Garantie

Tout produit qui s'avère défectueux en raison d'une défec-tuosité matérielle ou d'un vice de fabrication sera remplacé en vertu de notre politique de retour suite à l'évaluation de celui-ci par Therafin Corporation.

Cette garantie de remplacement n'est applicable que pour la première année à partir de la date d'achat, de plus, elle ne couvre pas les défauts ou les bris résultant de cas abus ou de négligence subis par le produit.

Document 08586
Revision A 4-2023



Therafin Corporation
9450 W Laraway Road
Frankfort, IL 60423 USA
800-843-7234
www.therafin.com



MedEnvoy Global B.V.
Prinses Margrietplantsoen 33- Suite 123
2595 AM The Hague
The Netherlands

Pivot Point Harness

Deutsch (German)

Bild unten zeigt installierte Gerät.

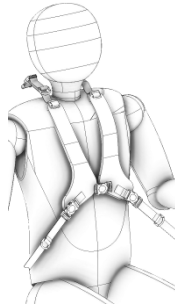

Produktkennung

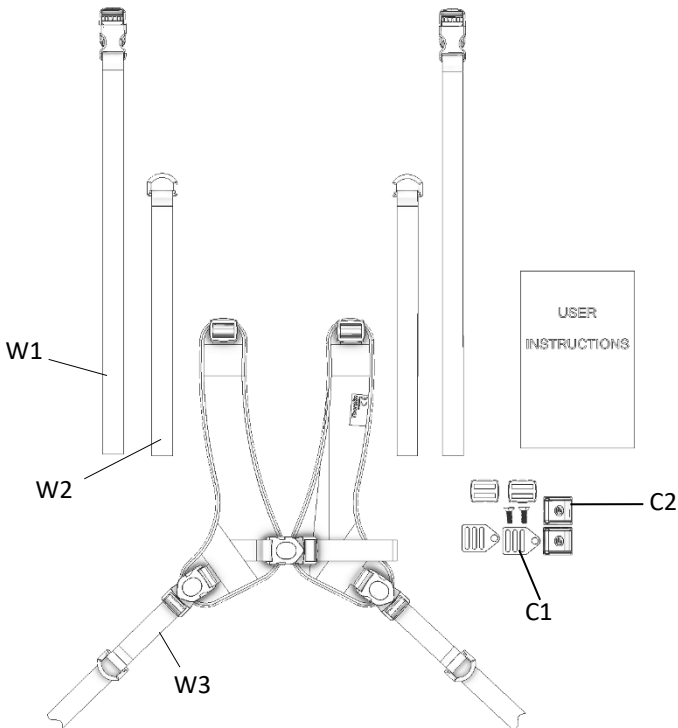

Pivot Point Harness

Aufstellen:

Wählen Sie Front-Pull oder Rear-Pull

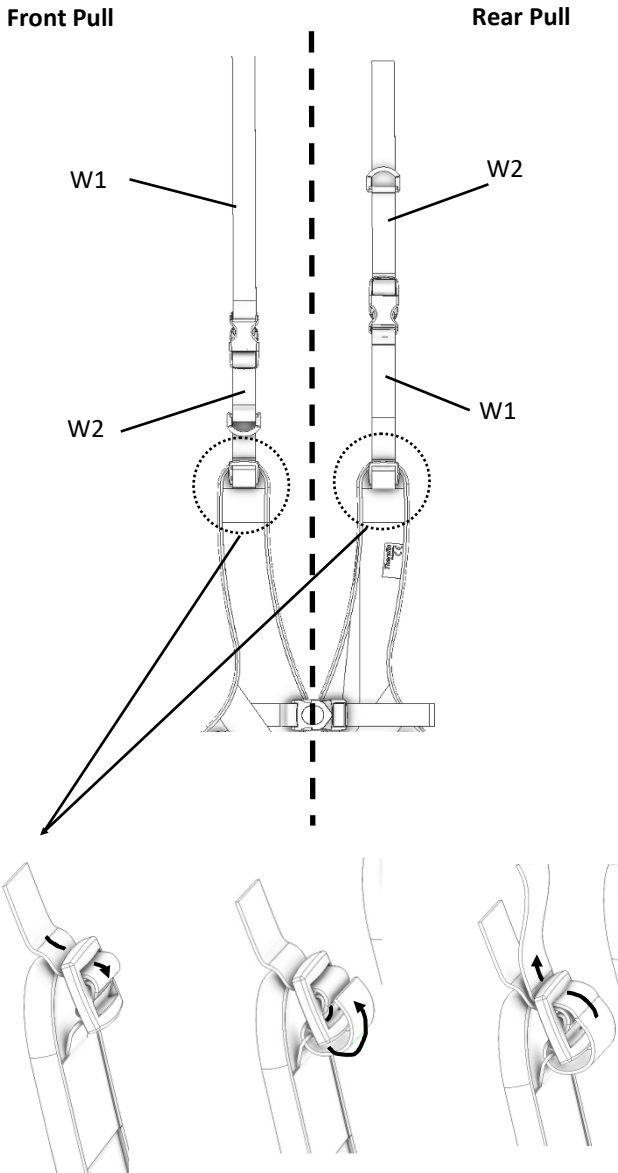

Pivot Point Harness



Achtung: Lesen Sie vor der Verwendung des Geräts die Anweisungen durch.



Achtung: Das Gerät sollte von einem geschulten Rollstuhltechniker angebracht werden.



Achtung: Das Gerät sollte an einer Rollstuhllehne angebracht werden, die ISO 16840-3 oder ähnlich entspricht.



Achtung: Gehen Sie beim Abringen, Entfernen oder Einstellen vorsichtig vor, um ein Einklemmen oder Verfangen der Finger zu vermeiden.



Achtung: Ziehen Sie stets alle Schrauben fest und prüfen Sie sie regelmäßig auf



Achtung: Dieses Gerät ist nicht als Rückhalte in einem fahrenden Fahrzeug vorgesehen. Dieses Gerät ist nur für den Gebrauch Positionierung und sollten nicht als Transitsicherheitsrückhalte verlassen. Verwenden Sie nur WC-3 geprüften Produkte für Insassenrückhalte in einem fahrenden Fahrzeug.



Warnung: Dieses Gerät sollte ordnungsgemäß getragen werden. Positionieren Sie das Gerät zur Vermeidung Erstickungsgefahr. Gerät sollte immer mit einem Hip Haltegurt verwendet werden.

Installieren:

SSchritt 1: Identifizieren der Anbringungsmethode:

2 Clips und 2 Cams (C1 und C2)

Schritt 2: Führen Sie das Gurtband (W1) durch die Clips (C1) und

W3 durch die Nocken (C2)..

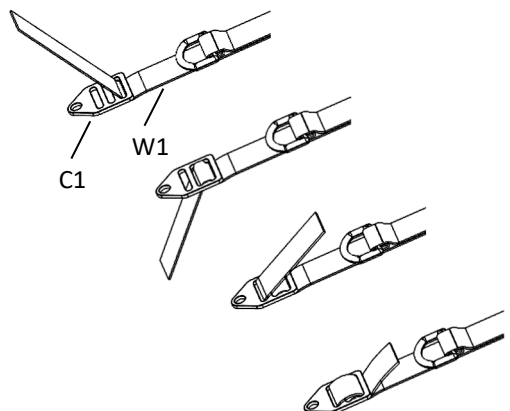
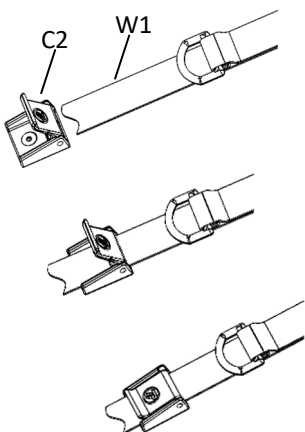

Pivot Point Harness

Schritt 3: Position Gerät auf Patienten. Stellen Sie keine zu hoch in der Nähe von Hals.



Warnung: Dieses Gerät sollte ordnungsgemäß getragen werden. Positionieren Sie das Gerät zur Vermeidung Erstickungsgefahr. Gerät

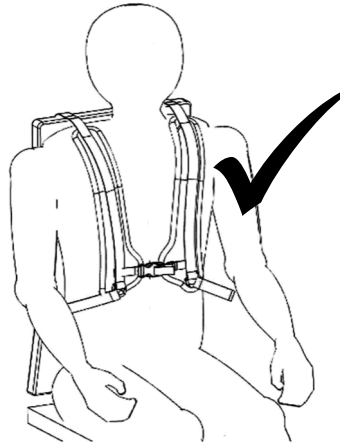
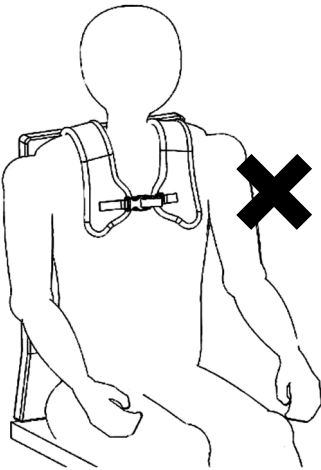

Schritt 4: Bringen Sie Clips (C1) und Nocken (C2) für Rollstuhl zurück. Ziehen Sie Befestigungselemente.

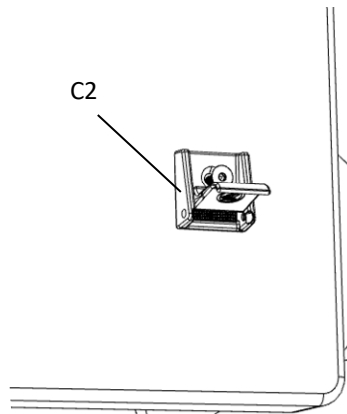
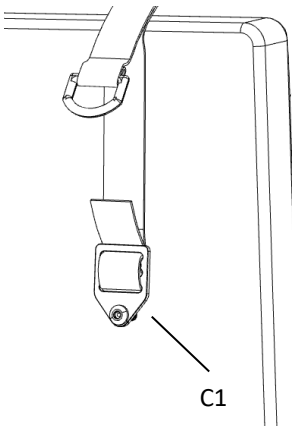

Pivot Point Harness

Einstellen:

Wenn alle Clips (C1) und Nocken (C2) gesichert sind, ziehen Riemen durch Ziehen am D-Ring. Achten Sie darauf, Weste nicht zu hoch in der Nähe von Hals positioniert.



Warnung: Dieses Gerät sollte ordnungsgemäß getragen werden. Positionieren Sie das Gerät zur Vermeidung Erstickungsgefahr. Gerät sollte immer mit einem Hip Haltegurt verwendet werden.

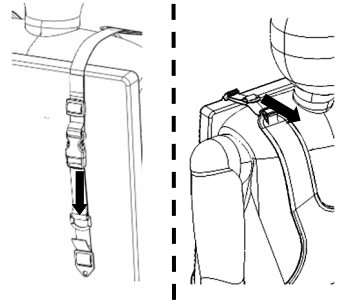

Pflege und Reinigung



Achtung: Ziehen Sie stets alle Schrauben fest und prüfen Sie sie regelmäßig auf festen Sitz.

1. Reinigung mit einem milden Reinigungsmittel und Wasser mit feuchten Tuch. Luft Trockene.

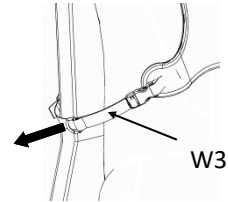

2. Überprüfen Sie alle Schrauben und ziehen Sie nach Bedarf.

Document 08586

Revision A 4-2023

Hinweise

Wenn der Patient Hautreizungen oder schwere Beschwerden verspürt, wenden Sie sich an Ihren Arzt oder Medizintechniker.

Bei schwerwiegenden Zwischenfällen oder Verletzungen wenden Sie sich bitte an Therafin Corp und die zuständige Behörde Ihres Landes

Das Produkt besteht aus Materialien, die ohne besondere Vorsichtsmaßnahmen sicher entsorgt werden können.



Therafin Corporation
9450 W Laraway Road
Frankfort, IL 60423 USA
800-843-7234
www.therafin.com

Garantie

Produkte, die innerhalb eines Jahres nach dem Kauf Material- oder Verarbeitungsfehler aufweisen, werden entsprechend unserer Umtauschrichtlinie nach Produktprüfung durch Therafin ersetzt. Diese Umtauschgarantie deckt keine Schäden durch falsche Handhabung oder Nachlässigkeit ab.



MedEnvoy Global B.V.
Prinses Margrietplantsoen 33- Suite 123
2595 AM The Hague
The Netherlands

Pivot Point Harness

Italiano (Italian)

Immagine sotto mostra dispositivo installato.

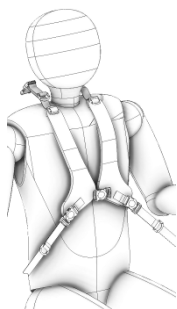

Identificazione del Prodotto

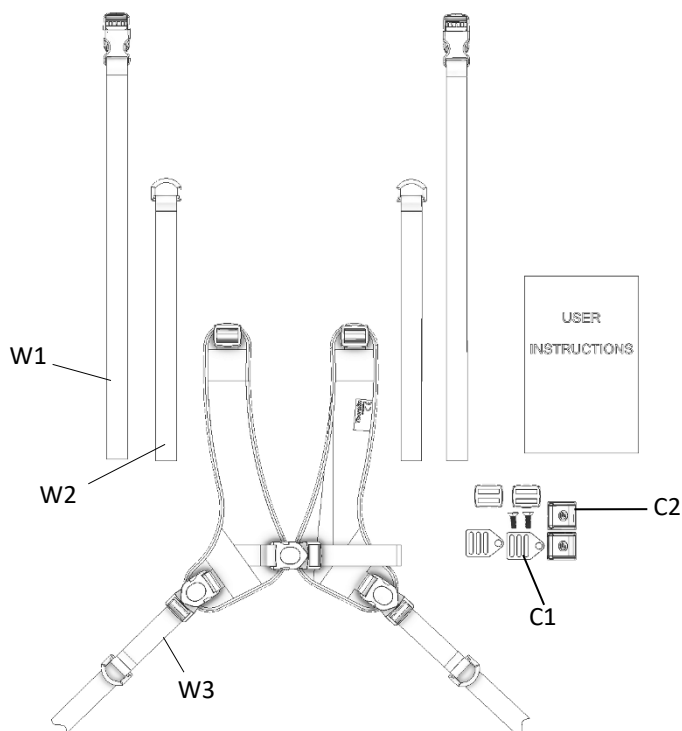

Pivot Point Harness

Impostare:





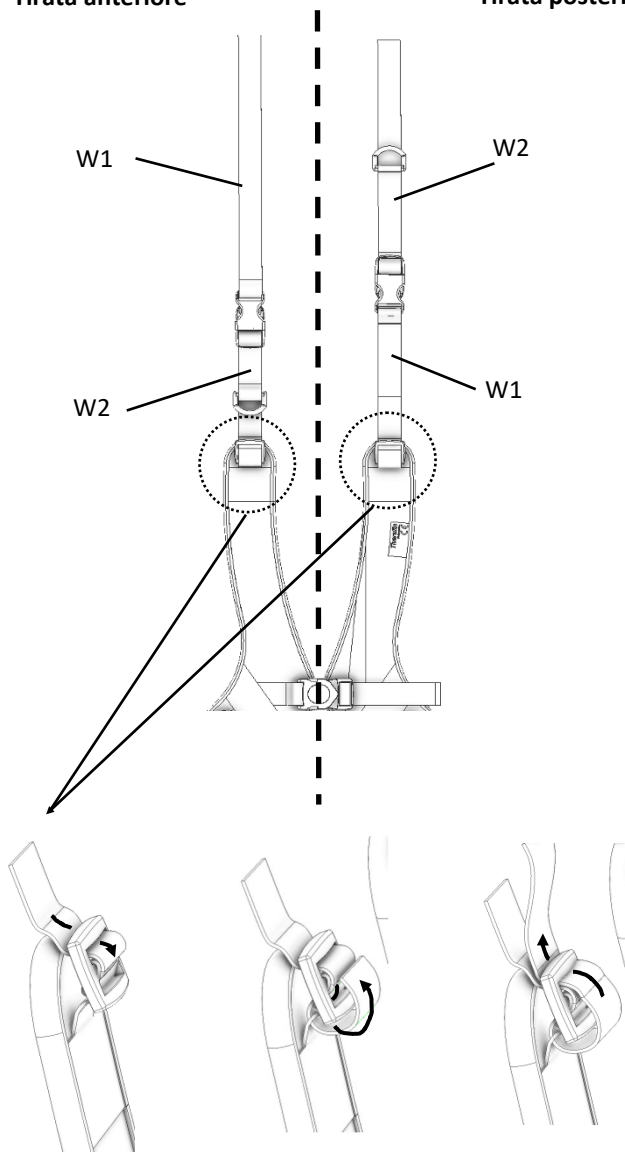

Scegli Trazione anteriore o Trazione posteriore

Tirata anteriore

Tirata posteriore



Pivot Point Harness

-  **Attenzione:** Leggere le istruzioni prima di attivare il dispositivo.
-  **Attenzione:** Il dispositivo deve essere installato da un tecnico specializzato in sedie a rotelle.
-  **Attenzione:** Il dispositivo deve essere attaccato alla parte posteriore della sedia a rotelle conformemente a ISO16840-3 o equivalente.
-  **Attenzione:** Siate cauti quando installate, togliete o regolate il dispositivo per evitare di pizzicarvi e intrappolare le dita.
-  **Attenzione:** Fissare sempre in modo sicuro le viti e ispezionarle regolarmente per verificare se sono state fissate
-  **Avvertenza:** questo dispositivo non è inteso come un sistema di ritenuta degli occupanti in un veicolo in movimento. Questo dispositivo è solo per uso posizionamento e non dovrebbe essere invocata come dispositivo di sicurezza del transito. Utilizzare solo WC-3 prodotti testati per ritenuta passeggeri in un veicolo in movimento.
-  **Avvertenza:** questo dispositivo deve essere indossato correttamente. Posizionare il dispositivo correttamente per evitare pericolo di soffocamento. Dispositivo deve essere sempre utilizzato con una cintura di posizionamento dell'anca.

Installare:

Passo 1: Selezionare il metodo di fissaggio:

2 clip e 2 camme (C1 e C2)

Passo 2: Far passare la fettuccia (W1) attraverso le clip (C1) e W3 attraverso le camme (C2).

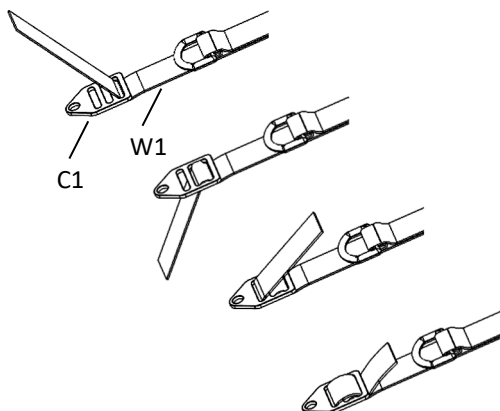
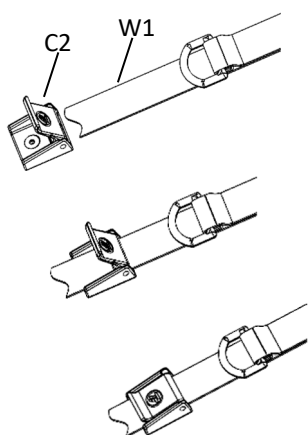

Pivot Point Harness

Passo 3: Dispositivo Posizione sulla paziente. Non mettere troppo in alto vicino al collo.

 **Avvertenza:** questo dispositivo deve essere indossato correttamente. Posizionare il dispositivo correttamente per evitare pericolo di soffocamento. Dispositivo deve essere sempre utilizzato con una cintura di posizionamento dell'anca.

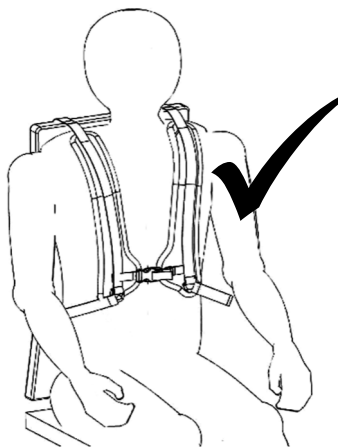
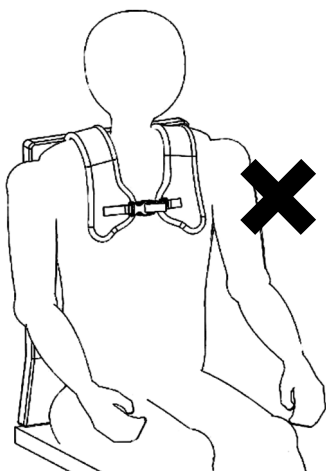

Passo 4: Fissare le clip (C1) e camme (C2) a sedia a rotelle posteriori. Serrare fermi.

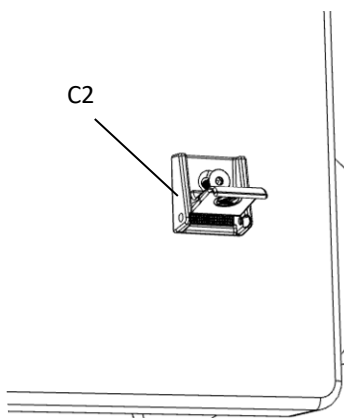
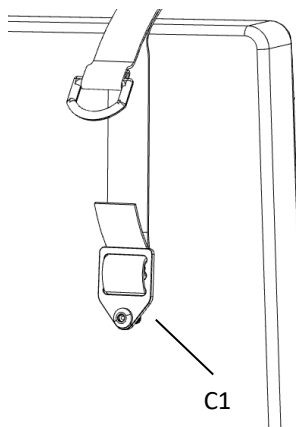

Pivot Point Harness

Regolare:

Una volta che tutti i fermagli (C1) e camme (C2) sono fissati, serrare cinghie (W1) tirando D-Ring. Assicurarsi gilet non sia posizionato troppo in alto vicino al collo.



Avvertenza: questo dispositivo deve essere indossato correttamente.

Posizionare il dispositivo correttamente per evitare pericolo di soffocamento.

Dispositivo deve essere sempre utilizzato con una cintura di posiziona-

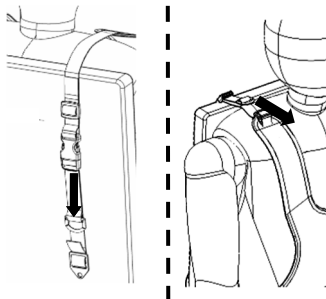

Cura e pulizia



Attenzione: Fissare sempre in modo sicuro le viti e ispezionarle regolarmente per verificare se sono state fissate.

1. Pulire con detergente delicato e acqua con un panno umido. Aria Secca.

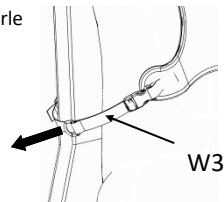

2. Controllare tutti i dispositivi di fissaggio e stringere di nuovo se necessario.

Document 08586

Revision A 4-2023

Avvisi

Se il paziente avverte irritazioni cutanee o gravi disturbi, contattare il proprio operatore sanitario o tecnico medico.

In caso di incidenti gravi o lesioni, contattare Therafin Corp e l'autorità competente per il proprio paese. Il prodotto è costituito da materiali che possono essere smaltiti in sicurezza senza particolari precauzioni.

Garanzia

Tutti i prodotti che risultano difettosi a causa del materiale o della manodopera entro un anno saranno sostituiti conformemente alla nostra modalità per la restituzione della merce venduta dopo una valutazione del prodotto svolta da Therafin Corporation. La presente garanzia di sostituzione del prodotto non include l'uso improprio o la trascuratezza durante l'uso del prodotto.



Therafin Corporation
9450 W Laraway Road
Frankfort, IL 60423 USA
800-843-7234
www.therafin.com



MedEnvoy Global B.V.
Prinses Margrietplantsoen 33- Suite 123
2595 AM The Hague
The Netherlands

Pivot Point Harness

Español (Spanish)

Imagen siguiente muestra el dispositivo instalado.

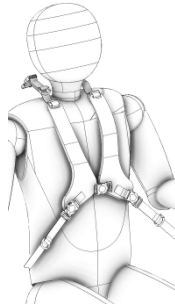

Product Identification

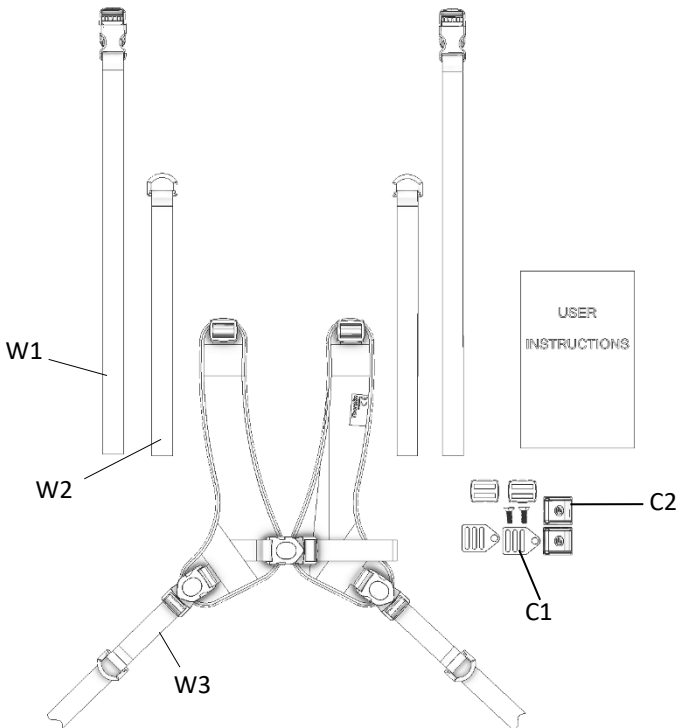

Pivot Point Harness

Configuración:

Elija Tirador delantero o Tirador trasero

Tirador delantero

Tirador trasero

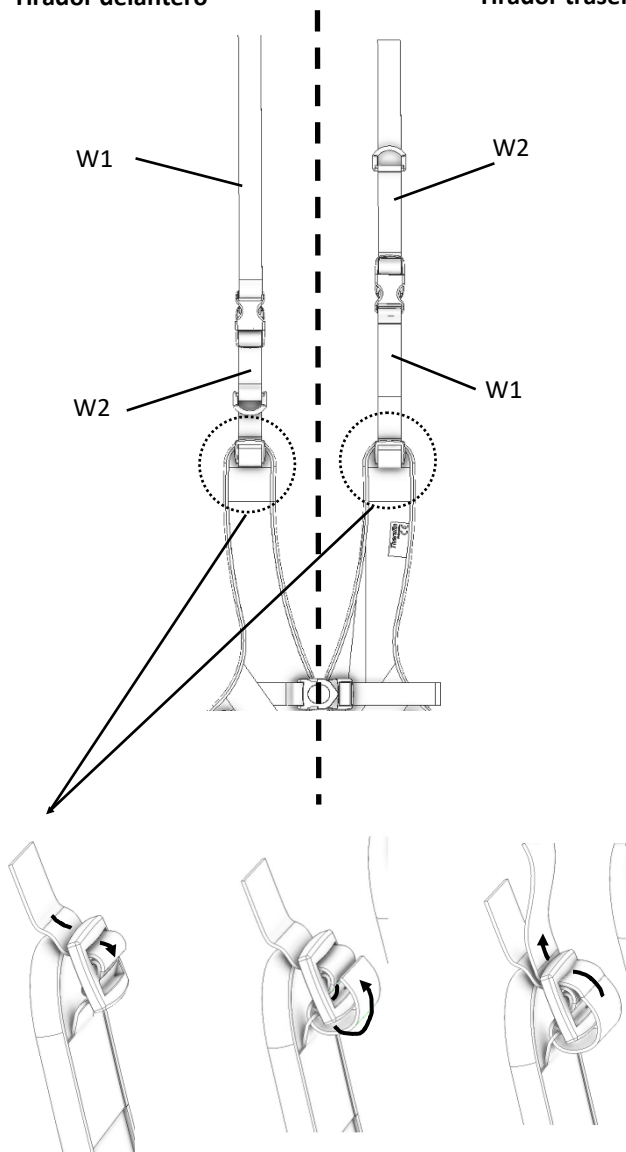

Pivot Point Harness



Precaución: Leer las instrucciones antes de operar el dispositivo.



Precaución: El dispositivo debe ser instalado por un técnico capacitado en sillas de rueda.



Precaución: El dispositivo debe adjuntarse al respaldar de una silla de ruedas que cumpla con las normas ISO 16840-3 o equivalentes.



Precaución: Actúe con precaución al instalar, retirar o ajustar el dispositivo para evitar pellizcarse o retener sus dedos.



Precaución: Ajustar siempre todos los sujetadores en forma segura e inspeccionar regularmente en busca de tensión.



Advertencia: Este dispositivo no está diseñado como una retención de ocupantes de un vehículo en movimiento. Este dispositivo es sólo para uso posicionamiento y no debe ser considerada como un producto de seguridad de tránsito. Utilice sólo WC-3 productos probados para sujeción del ocupante en un vehículo en movimiento.



Advertencia: Este dispositivo debe ser usado correctamente. Coloque el dispositivo correctamente para evitar peligro de asfixia. Dispositivo siempre debe utilizarse con un cinturón de posicionamiento de la cadera.

Instalar:

Paso 1: identificar el método de unión:

2 Clips (C1) y 2 Cams (C2)

Paso 2: Pase la correa (W1) a través de los clips (C1) y W3 a través de las levas (C2).

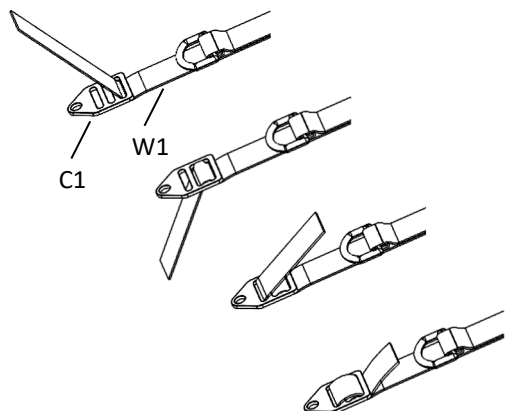
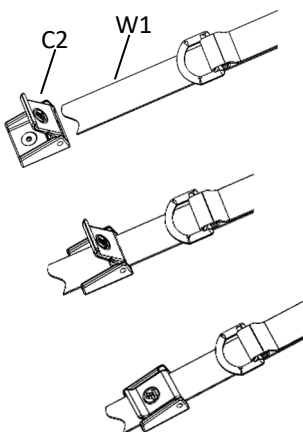

Pivot Point Harness

Paso 3: Coloque el dispositivo en el paciente. No ponga demasiado alto, cerca de la garganta.



Advertencia: Este dispositivo debe ser usado correctamente. Coloque el dispositivo correctamente para evitar peligro de asfixia. El dispositivo siempre debe utilizarse con un cinturón de posicionamiento de la cadera.

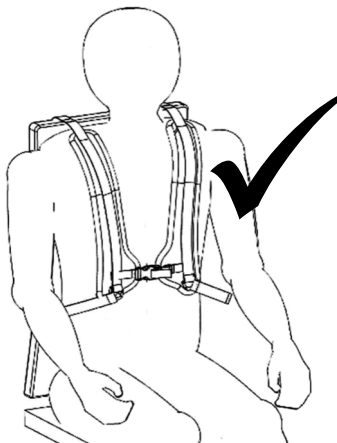
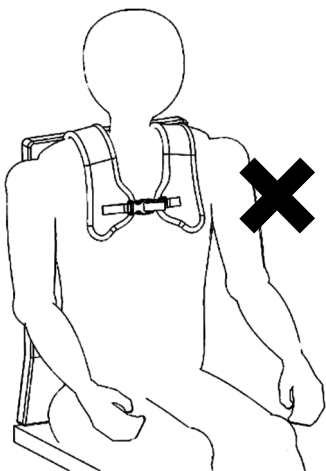

Paso 4: Adjuntar clips (C1) y levas (C2) a la silla de ruedas traseras. Apriete los sujetadores.

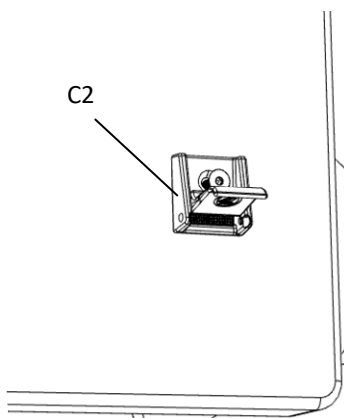
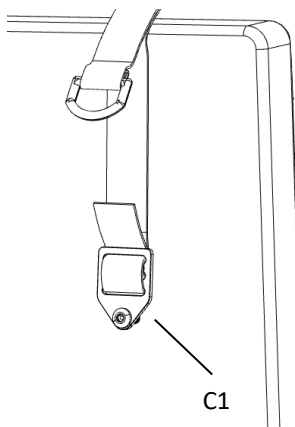

Pivot Point Harness

Ajustar:

Una vez que todos los clips (C1) y levas (C2) están asegurados, apretar las correas (W1) tirando de D-Ring. Asegúrese chaleco NO está colocado demasiado alto, cerca de la garganta.



Advertencia: Este dispositivo debe ser usado correctamente. Coloque el dispositivo correctamente para evitar peligro de asfixia. Dispositivo siempre debe utilizarse con un cinturón de posicionamiento de la cadera.

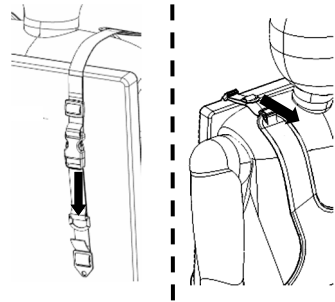

Cuidado y limpieza



Precaución: Ajustar siempre todos los sujetadores en forma segura e inspeccionar regularmente en busca de tensión.

1. Limpiar con un detergente suave y agua usando un paño húmedo. Aire Seco.

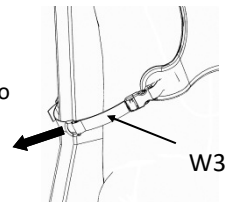

2. Compruebe que todos los tornillos y vuelva a apretar según sea necesario

Document 08586

Revision A 4-2023

Avisos

Si el paciente experimenta alguna irritación de la piel o molestias graves, póngase en contacto con su profesional sanitario o técnico médico.

Si ocurre algún incidente o lesión grave, comuníquese con Therafin Corp y la autoridad competente de su país.

El producto está fabricado con materiales que se pueden eliminar de forma segura sin precauciones especiales.

Garantía

Cualquier producto que se encuentre defectuoso debido al material o mano de obra dentro de un año será reemplazado de conformidad con nuestra política tras la evaluación del producto por parte de Therafin Corporation. Esta garantía de sustitución no incluye el mal uso o descuido del producto.



Therafin Corporation
9450 W Laraway Road
Frankfort, IL 60423 USA
800-843-7234
www.therafin.com



MedEnvoy Global B.V.
Prinses Margrietplantsoen 33- Suite 123
2595 AM The Hague
The Netherlands

Document 08586
Revision A 4-2023



Therafin Corporation
9450 W Laraway Road
Frankfort, IL 60423 USA
800-843-7234
www.theraфин.com



MedEnvoy Global B.V.
Prinses Margrietplantsoen 33- Suite 123
2595 AM The Hague
The Netherlands